

# Installation and Safety Guide

## LMC Series Linear Motor

Thank you for choosing HIWIN linear motor product. Read and understand the motor specification, the user manual, and the Safety/Warning Notice statements before installing and using the product.

Safety symbols				
Caution	Risk of electric shock	Caution, strong magnetic field	Caution, hot surface	Don't Touch

### ★ Precautions and Warning

	<ol style="list-style-type: none"> <li>Before using this product, be sure to read and understand the user manual. Strictly adhere to the statements given in the manual. HIWIN is not responsible for any damage, accident, or injury caused by incorrect handling.</li> <li>Before installing and operating this product, perform cosmetic inspection. If any signs of damaged, please contact HIWIN customer service or local agent.</li> <li>The product designs are based on structural calculations, computer simulations and experimental testing. Do not disassemble or modify product by oneself without permission from HIWIN.</li> </ol>
	<ol style="list-style-type: none"> <li>Do not install forcer assembly, before you ensure that the power has been disconnected, otherwise there is risk of electrical shock.</li> </ol>
	<ol style="list-style-type: none"> <li>The magnetic attraction between the magnet and other magnetic or ferrous materials is extremely high. Keep fingers and other body parts away that are wearing magnetic objects (steel objects) from the stators to avoid injury by the magnetic attraction.</li> </ol>
	<ol style="list-style-type: none"> <li>Keep out of reach of children from handling this product.</li> <li>Anyone with a pacemaker or A.I.C.D. is prohibited to use this product.</li> </ol>

### ★ User Guide Criteria

	<ol style="list-style-type: none"> <li>Stator assembly has strong magnet field, be sure to handle with care.</li> <li>Put warning labels on the top surface of stator assembly for reminder of magnetic dangers.</li> <li>Keep magnetic storage media or precision instrument away from the product to avoid damage caused by magnetic fields. (i.e. magnet scale, watch, credit card and magnetic response device).</li> <li>During assembly of stator to system structure, keep any magnetic material at a distance</li> <li>During assembly, avoid using magnetic tools and screws.</li> </ol>
	<ol style="list-style-type: none"> <li>Do not bend or damage the cables of forcer assembly.</li> <li>Do not run the continuous current of forcer higher than specified in datasheet.</li> <li>Be sure to confirm that there is no interference with other components in operation. And confirm that the cable bending radius is large enough to prevent reducing the life of the cables.</li> <li>When abnormal smell, noise, smoke and vibration is detected, press emergency stop button and turn off power.</li> <li>The product can only be repaired by HIWIN engineers. Please send the product back to HIWIN if there is any unusual phenomenon.</li> <li>A one year guarantee is provided from the date of delivery. HIWIN will not be held responsible for replacing or maintaining product which has been incorrectly handled (please refer to the notes and instructions in the operation manual) or damage from natural disasters.</li> </ol>
	<ol style="list-style-type: none"> <li>Do not touch the forcer or stator during operation.</li> </ol>
	<ol style="list-style-type: none"> <li>Operate within specified temperature range.</li> <li>After finishing operation, allow forcer to cool down sufficiently (in a 25°C room temperature) before working around the product, to avoid getting burned.</li> </ol>

## 1- Mechanism interface accuracy

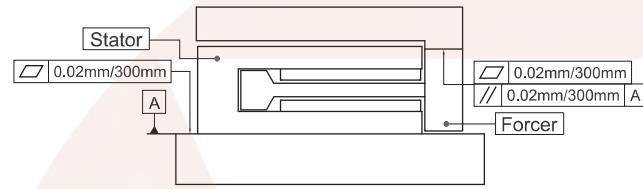

Fig1. Installation Interface geometric accuracy

**1-1** Installation interface with stator should have flatness of 0.02mm per 300mm, as shown in Fig1.

**1-2** Installation interface with forcer should have flatness of 0.02mm per 300mm and accuracy of 0.02mm per 300mm with reference to datum A as shown in Fig1.

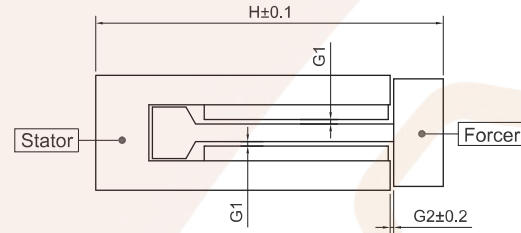
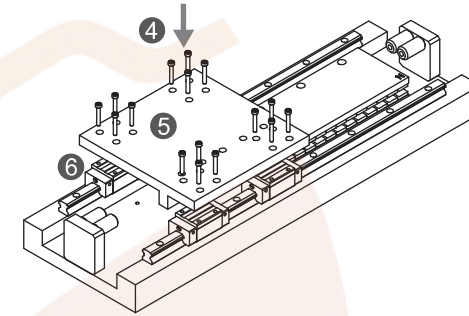

Fig2. Forcer and stator assembled dimension

**1-3** Notice H, G1 and G2 dimensions between forcer and stator after assembly, they will impact linear motor performance and reliability, please refer to Appendix A and Fig2.

**2-3** Use screw ④ to install forcer plate ⑤ on guide block ⑥.

Refer to Appendix B for table of screw torques to assemble stator and forcer.



**2-4** Move forcer plate ⑦ to the left side to ease installation of forcer ⑧.

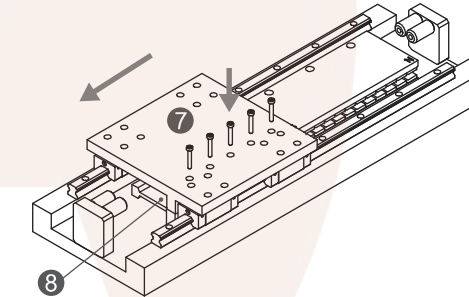

**2-5** Check that the forcer ⑨ can move freely over the entire stroke and stop on right side for another stator assembly.

Please reference 1-3 after assembling forcer and stator, please note air gap between forcer and stator. Refer to Appendix B for table of screw torques to assemble stator and forcer.

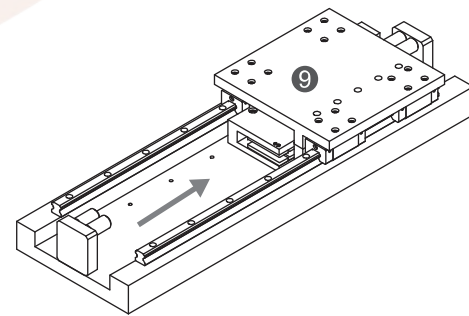

## 2- Installation step

**2-1** Clean stator surface by using disposable cotton rags applied with allowed cleaning liquid such as isopropanol alcohol (95% Vol.)

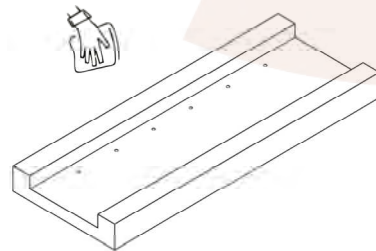

**2-2** Install right side of stator ② to base frame ③ by screw ①.

Warning signs label of stator is required to be placed on the top surface of stator. Refer to Appendix B for table of screw torques to assemble stator and forcer.

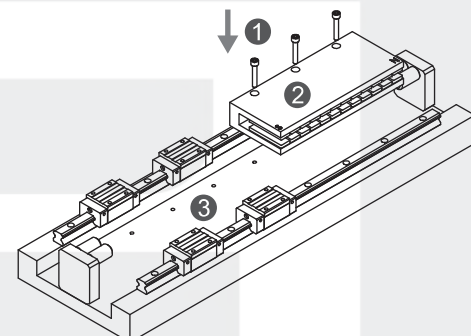

**2-6** Assemble every stator ⑩ by fixing on base frame ⑪.

Please be careful when handling the stator assembly to avoid getting clamped.

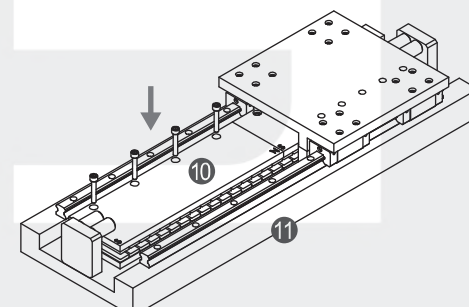

**2-7** Check that the forcer can move freely over the entire stroke after assembly is finished.

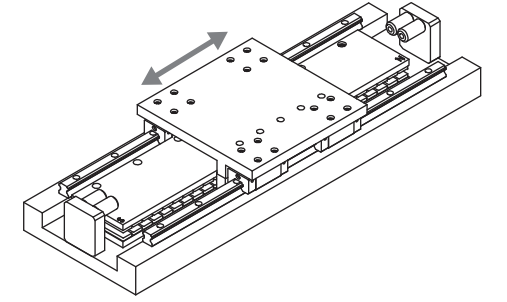

Regarding screws depth and pitch, please refer to Catalog.

### ★ APPENDIX A

Model	Size (mm)		
	H	G1	G2
LMCA	74.5	≥0.4	1
LMCB	94.5	≥0.4	1
LMCC	117.5	≥0.4	1
LMCD	105	≥0.4	1.2
LMCE	125	≥0.4	1.2
LMCF	172	≥0.4	1.2
LMC-EFC	68.5	≥0.4	1.3
LMC-EFE	93	≥0.4	1.3

### ★ APPENDIX B

Table of screw torques for assembly of forcer and stator (Refer DIN912) Bolt strength class12.9	
Screw size	Torque(kgf-cm)
M3x0.5P	15.3
M4x0.7P	36.7
M5x0.8P	70.6
M6x1.0P	124
M8x1.25P	301



**HIWIN**  
Motion Control and System Technology

**HIWIN MIKROSYSTEM CORP.**

HIWIN RUSSIA  
+7(495) 407-01-02  
www.zetek.ru  
www.servosystem.ru